

- N°4 BORCHIE - ALTEZZA H = 7.5
FORI Ø6.5 - INTERASSE Ø338.9 ±0.1
- N°4 BOSSES - HEIGHT H = 7.5
HOLES Ø6.5 - INTERAXLE Ø338.9 ±0.1

- N°4 GANCI PER PERNI Ø6
INTERASSE Ø340.1 ±0.1
- N°4 HOOKS Ø6
INTERAXLE Ø340.1 ±0.1

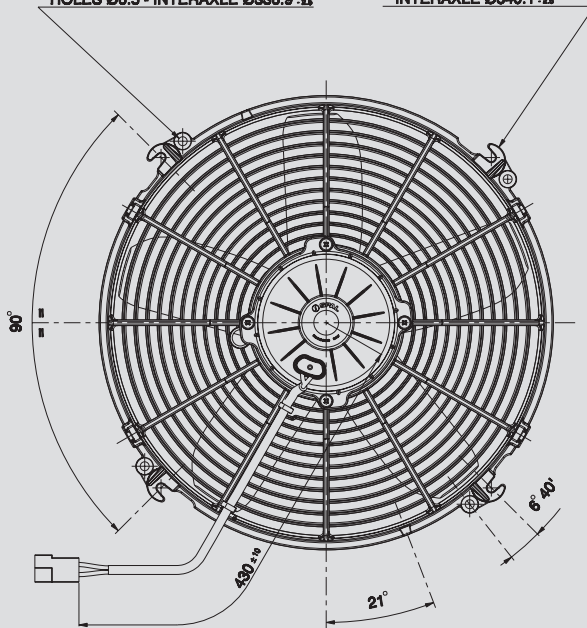

SEDE PER ANELLO IN GOMMA
RUBBER RING HOUSING

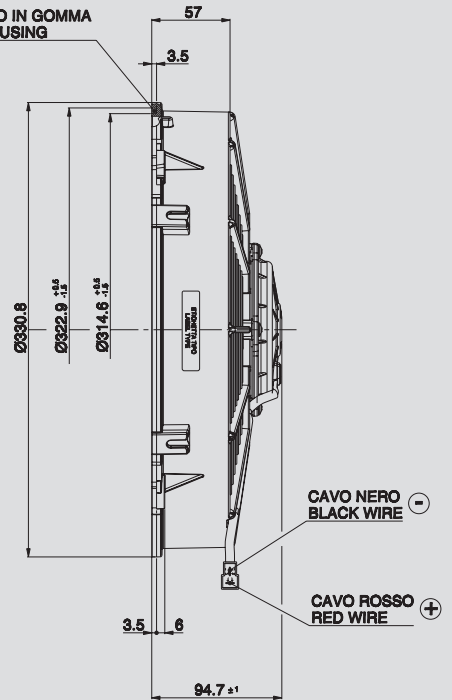

Ø 305 mm

Ø 12"

AMP connector Code 180908
AMP terminal Code 42098-2
Suggested mounting torque: 3(+1/-0) Nm with screw M5
Weight 2,35 Kg. approx.

Connettore AMP Cod. 180908
Terminali AMP Cod. 42098-2
Coppia di serraggio consigliata: 3(+1/-0) Nm con vite M5
Peso 2,35 Kg. circa

PRODUCT FEATURES
CARATTERISTICHE PRODOTTO

suction / aspirante

blowing / soffiante

Waterproof motor, IP 68
Motore chiuso, IP 68



Long life / Lunga durata



VLL version* / Versione VLL*



Waterproof connector
Connettori a tenuta stagna



Accessories: all the fixing kits
Accessori: tutti i kit di fissaggio



Static pressure Pressione statica mm H ₂ O	suction / aspirante			blowing / soffiante			Static pressure Pressione statica inH ₂ O
	Airflow Portata m ³ /h	Current input Corrente assorbita A	Airflow Portata CFM	Airflow Portata m ³ /h	Current input Corrente assorbita A	Airflow Portata CFM	
0	2580	8,2	1522	2440	7,8	1440	0
5	2340	8,4	1381	2210	8,1	1304	0,2
10	2020	8,5	1192	1940	8,3	1145	0,4
15	1580	8,4	932	1590	8,3	938	0,6
20	1170	8,8	690	1180	8,6	696	0,8
25	880	9,1	519	810	8,8	478	1
30	660	9,6	389	510	9,2	301	1,2
35	370	10,0	218	190	9,8	112	1,4
40	200	10,3	118	0	10,5	0	1,6
45	0	11,0	0				1,8

* for OEM applications only.
* per applicazioni OEM

✓ = Standard feature
Caratteristiche standard

✓ = Available upon request
Disponibile su richiesta

Test voltage 26 V. D.C. - Tensione di prova 26 V. c.c.