

12V C.C. - D.C.

VA22-AP11/C-50A  
VA22-AP11/C-50S

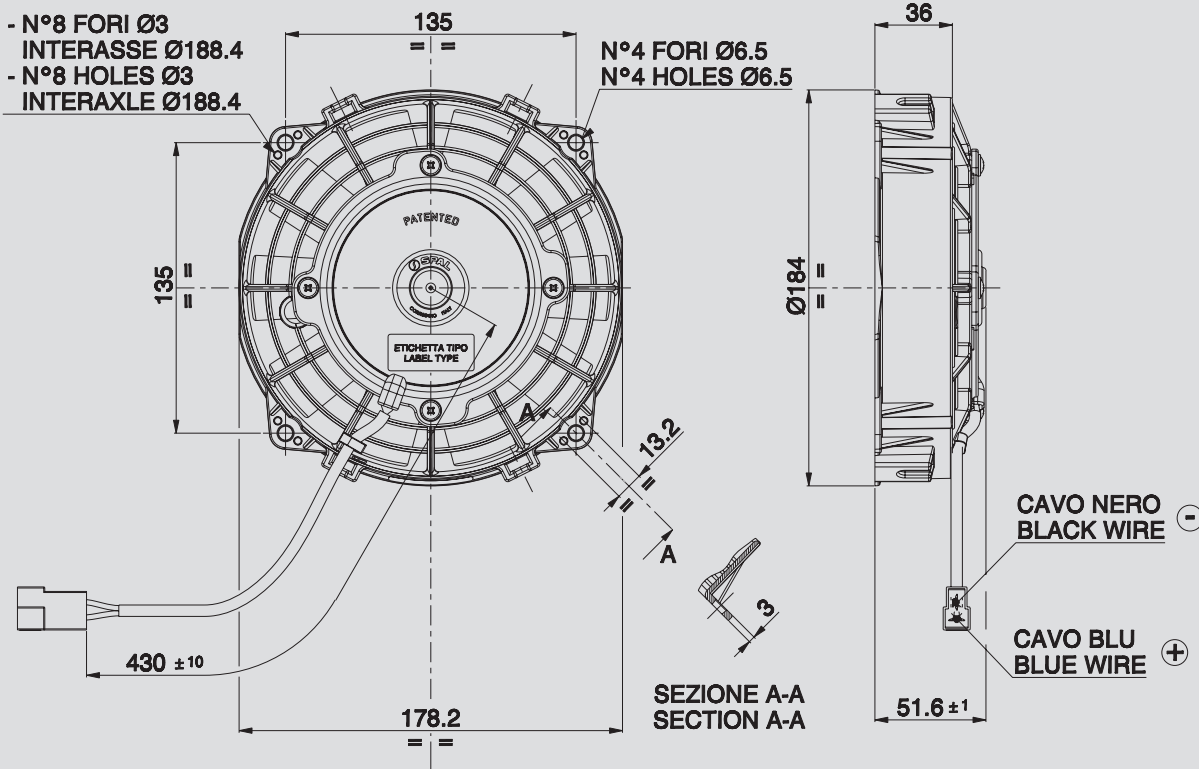

AMP connector Code 180908  
AMP terminal Code 42098-2  
Suggested mounting torque: 3(+1/-0) Nm with screw M5  
Weight 0,80 Kg. approx.

Connettore AMP Cod. 180908  
Terminali AMP Cod. 42098-2  
Coppia di serraggio consigliata: 3(+1/-0) Nm con vite M5  
Peso 0,80 Kg. circa

Ø 167 mm  
Ø 6,5"

suction / aspirante

blowing / soffiante

PRODUCT FEATURES  
CARATTERISTICHE PRODOTTO

Static pressure Pressione statica mm H <sub>2</sub> O	suction / aspirante			blowing / soffiante			Static pressure Pressione statica inH <sub>2</sub> O
	Airflow Portata m <sup>3</sup> /h	Current input Corrente assorbita A	Airflow Portata CFM	Airflow Portata m <sup>3</sup> /h	Current input Corrente assorbita A	Airflow Portata CFM	
0	530	5,0	313	510	5,1	301	0
2,5	490	5,4	289	480	5,4	283	0,1
5	460	5,3	271	430	5,2	254	0,2
7,5	430	5,5	254	410	5,3	242	0,3
10	370	5,6	218	320	5,4	189	0,4
12,5	330	5,5	195	250	5,2	148	0,5
15	290	5,3	171	190	5,6	112	0,6
20	220	5,6	130	140	5,7	83	0,8
25	130	5,8	77	0	6,1	0	1
30	0	5,9	0				

Waterproof motor, IP 68 Motore chiuso, IP 68	✓
Long life / Lunga durata	✓
LL and VLL version* Versione LL e VLL*	✓
Waterproof connector Connettori a tenuta stagna	✓
Accessories: all the fixing kits Accessori: tutti i kit di fissaggio	✓

\* for OEM applications only.  
\* per applicazioni OEM

✓ = Standard feature  
Caratteristiche standard  
✓ = Available upon request  
Disponibile su richiesta

Test voltage 13 V. d.c. - Tensione di prova 13 V. c.c.